

FH CONNECTOR

0.5mm pitch/Connectors for FPC

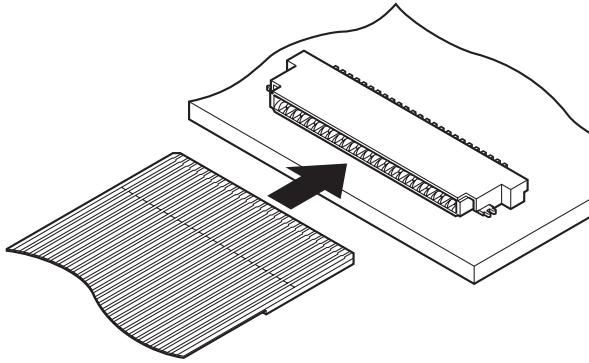

The large miniaturization at pitch direction and depth direction and low profile as 1.2mm mounting height are realized. FH connector is miniaturized and space saving Non-ZIF type connector for FPC.

- Double-sided contact
- Applicable to standard FPC

Specifications

- Current rating: 0.5A AC, DC
 - Voltage rating: 50V AC, DC
 - Temperature range: -25°C to +85°C
(including temperature rise in applying electrical current)
 - Contact resistance: Initial value/40m Ω max.
After environmental testing/20m Ω max.
(variation from initial value)
 - Insulation resistance: 500M Ω min.
 - Withstanding voltage: 200V AC/minute
 - Applicable FPC: Conductor pitch/0.5mm
Conductor width/0.35mm
Mating part thickness/0.3±0.05mm
- * Compliant with RoHS.
* Refer to "General Instruction and Notice when using Terminals and Connectors" at the end of this catalog.
* Contact JST for details.

Standards

Recognized E60389

Certified LR20812

PC board layout (viewed from component side) and Assembly layout

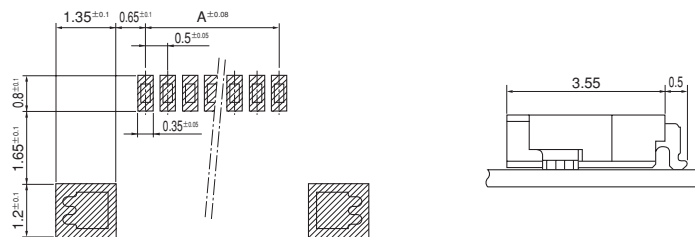

- Note: 1. Tolerances are non-cumulative: ±0.08mm for all centers.
2. The dimensions above should serve as a guideline. Contact JST for details.

FH CONNECTOR

Connector

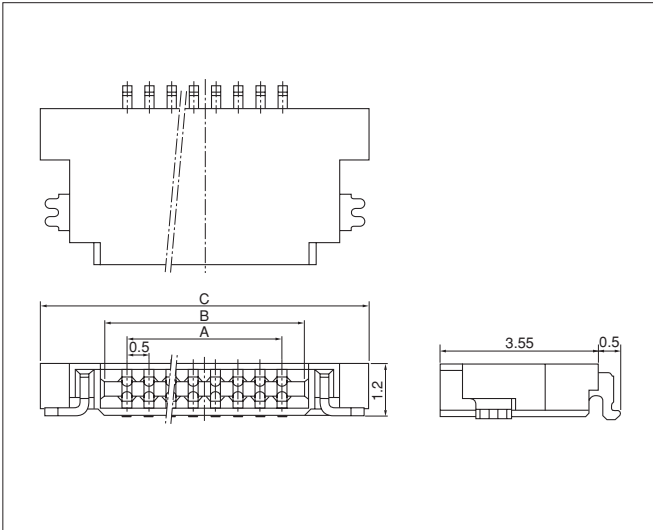

Circuits	Model No.	Dimensions (mm)			Q'ty / reel
		A	B	C	
5	05FH-SM1-TB	2.0	3.0	5.9	4,000
6	06FH-SM1-TB	2.5	3.5	6.4	4,000
7	07FH-SM1-TB	3.0	4.0	6.9	4,000
8	08FH-SM1-TB	3.5	4.5	7.4	4,000
10	10FH-SM1-TB	4.5	5.5	8.4	4,000
11	11FH-SM1-TB	5.0	6.0	8.9	4,000
12	12FH-SM1-TB	5.5	6.5	9.4	4,000
14	14FH-SM1-TB	6.5	7.5	10.4	4,000
16	16FH-SM1-TB	7.5	8.5	11.4	4,000
18	18FH-SM1-TB	8.5	9.5	12.4	4,000
20	20FH-SM1-TB	9.5	10.5	13.4	4,000
25	25FH-SM1-TB	12.0	13.0	15.9	4,000

Material and Finish

Contact: Copper alloy, copper-undercoated, tin-plated (reflow treatment)
Housing: LCP, UL94V-0
Solder tab: Copper alloy, copper-undercoated, tin-plated (reflow treatment)

RoHS compliance This product displays (LF)(SN) on a label.

Lead section dimensions of FPC

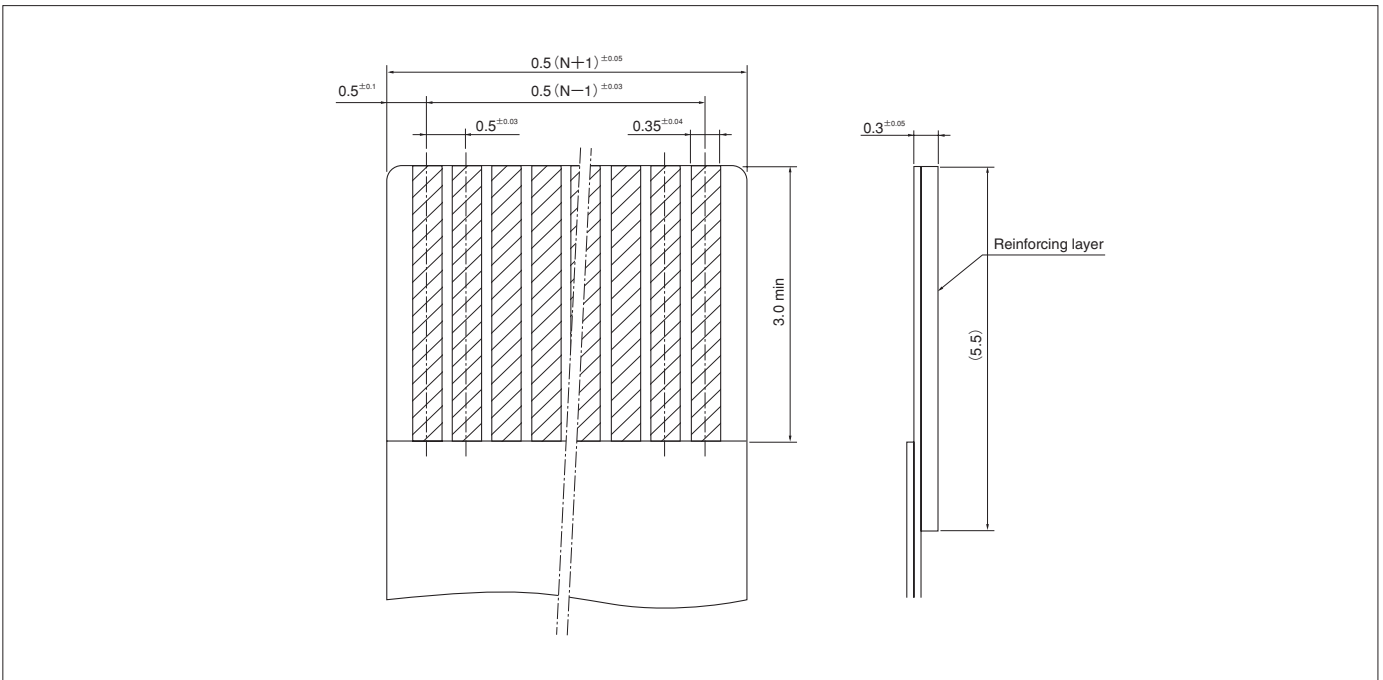

Note: N --- Number of circuits