

RMU500-EK User Guide

5G Module Series

Version: 1.0

Date: 2020-11-23

Status: Released



Our aim is to provide customers with timely and comprehensive service. For any assistance, please contact our company headquarters:

Quectel Wireless Solutions Co., Ltd.

Building 5, Shanghai Business Park Phase III (Area B), No.1016 Tianlin Road, Minhang District, Shanghai 200233, China

Tel: +86 21 5108 6236

Email: info@quectel.com

Or our local office. For more information, please visit:

<http://www.quectel.com/support/sales.htm>.

For technical support, or to report documentation errors, please visit:

<http://www.quectel.com/support/technical.htm>

Or email to support@quectel.com.

General Notes

Quectel offers the information as a service to its customers. The information provided is based upon customers' requirements. Quectel makes every effort to ensure the quality of the information it makes available. Quectel does not make any warranty as to the information contained herein, and does not accept any liability for any injury, loss or damage of any kind incurred by use of or reliance upon the information. All information supplied herein is subject to change without prior notice.

Disclaimer

While Quectel has made efforts to ensure that the functions and features under development are free from errors, it is possible that these functions and features could contain errors, inaccuracies and omissions. Unless otherwise provided by valid agreement, Quectel makes no warranties of any kind, implied or express, with respect to the use of features and functions under development. To the maximum extent permitted by law, Quectel excludes all liability for any loss or damage suffered in connection with the use of the functions and features under development, regardless of whether such loss or damage may have been foreseeable.

Duty of Confidentiality

The Receiving Party shall keep confidential all documentation and information provided by Quectel, except when the specific permission has been granted by Quectel. The Receiving Party shall not access or use Quectel's documentation and information for any purpose except as expressly provided herein. Furthermore, the Receiving Party shall not disclose any of the Quectel's documentation and information to any third party without the prior written consent by Quectel. For any noncompliance to the above requirements, unauthorized use, or other illegal or malicious use of the documentation and information, Quectel will reserve the right to take legal action.

Copyright

The information contained here is proprietary technical information of Quectel wireless solutions co., ltd. Transmitting, reproducing, disseminating and editing this document as well as using the content without permission are forbidden. Offenders will be held liable for payment of damages. All rights are reserved in the event of a patent grant or registration of a utility model or design.

Copyright © Quectel Wireless Solutions Co., Ltd. 2020. All rights reserved.

About the Document

Revision History

Version	Date	Author	Description
-	2019-12-19	Tom TANG/ Shaky LIN	Creation of the document
1.0	2020-11-23	Tom TANG/ Shaky LIN	First official release

Contents

About the Document.....	3
Contents.....	4
Table Index.....	5
Figure Index.....	6
1 Introduction	7
1.1. Safety Information	7
2 General Overview.....	9
2.1. Key Features	9
2.2. Component Placement of the EVB	10
2.3. Top View of the EVB	11
2.4. EVB Kit Accessories.....	11
3 Components/Interfaces	13
3.1. Components/Interfaces of the EVB.....	13
3.1.1. Power Supply (J101/J301).....	13
3.1.2. M.2 Interface (J201).....	14
3.1.3. USB Interface (J301).....	14
3.1.4. (U)SIM Interface (J401).....	15
3.1.5. Status Indicator (D104/D107)	17
3.1.6. RF Cables and Antennas.....	18
3.1.6.1. Antenna Design	18
3.1.6.2. Antenna Efficiency.....	18
3.1.6.3. Antenna Specification.....	19
3.2. Component Assembling Steps.....	20
4 EVB Operation Procedures.....	24
4.1. Turn on the Module	24
4.2. Communication Via the USB Interface	24
4.3. Firmware Upgrade.....	25
4.4. Turn Off the Module	26
5 Appendix References	27

Table Index

Table 1: Key Features	9
Table 2: Interfaces and Functions of the EVB	10
Table 3: Accessories List	11
Table 4: Pin Definition of J401	16
Table 5: Description of Status Indicator LEDs	17
Table 6: Antenna Specification	19
Table 7: Related Documents.....	27
Table 8: Terms and Abbreviations	27

Figure Index

Figure 1: Component Placement of the EVB (Top View)	10
Figure 2: EVB Top View	11
Figure 3: EVB Power Supply Interfaces.....	13
Figure 4: M.2 Connector on the EVB	14
Figure 5: USB Connector	14
Figure 6: Connection Between PC and EVB	15
Figure 7: Simplified Connecting Schematic for (U)SIM Card Connector J401.....	15
Figure 8: Pin Assignment of (U)SIM Card Connector J401	16
Figure 9: Status Indicators	17
Figure 10: Reference Design for Antennas	18
Figure 11: Antenna Efficiency at 700–960 MHz and 1.7–6 GHz.....	18
Figure 12: Antenna Efficiency at 1.7–6 GHz.....	19
Figure 13: Assembling Step 1	20
Figure 14: Assembling Step 2.....	21
Figure 15: Assembling Step 3.....	21
Figure 16: Assembling Step 4.....	22
Figure 17: Assembling Step 5.....	22
Figure 18: Assembling Step 6.....	23
Figure 19: USB Ports	24
Figure 20: COM Port Setting Field on QCOM (USB AT Port Connection).....	25
Figure 21: Configurations for Firmware Upgrade	25

1 Introduction

This document introduces the evaluation board RMU500-EK for RM500Q-GL, the assistant tool for developers to develop and test the modules, and describes how to use it.

1.1. Safety Information

The following safety precautions must be observed during all phases of the operation, such as usage, service or repair of any cellular terminal or mobile incorporating the module. Manufacturers of the cellular terminal should notify users and operating personnel of the following safety information by incorporating these guidelines into all manuals of the product. Otherwise, Quectel assumes no liability for customers' failure to comply with these precautions.



Full attention must be paid to driving at all times in order to reduce the risk of an accident. Using a mobile while driving (even with a handsfree kit) causes distraction and can lead to an accident. Please comply with laws and regulations restricting the use of wireless devices while driving.



Switch off the cellular terminal or mobile before boarding an aircraft. The operation of wireless appliances in an aircraft is forbidden to prevent interference with communication systems. If there is an Airplane Mode, it should be enabled prior to boarding an aircraft. Please consult the airline staff for more restrictions on the use of wireless devices on an aircraft.



Wireless devices may cause interference on sensitive medical equipment, so please be aware of the restrictions on the use of wireless devices when in hospitals, clinics or other healthcare facilities.



Cellular terminals or mobiles operating over radio signal and cellular network cannot be guaranteed to connect in certain conditions, such as when the mobile bill is unpaid or the (U)SIM card is invalid. When emergent help is needed in such conditions, use emergency call if the device supports it. In order to make or receive a call, the cellular terminal or mobile must be switched on in a service area with adequate cellular signal strength. In an emergency, the device with emergency call function cannot be used as the only contact method considering network connection cannot be guaranteed under all circumstances.



The cellular terminal or mobile contains a transceiver. When it is ON, it receives and transmits radio frequency signals. RF interference can occur if it is used close to TV sets, radios, computers or other electric equipment.



In locations with explosive or potentially explosive atmospheres, obey all posted signs and turn off wireless devices such as mobile phone or other cellular terminals. Areas with explosive or potentially explosive atmospheres include fuelling areas, below decks on boats, fuel or chemical transfer or storage facilities, and areas where the air contains chemicals or particles such as grain, dust or metal powders.

2 General Overview

Quectel supplies RMU500-EK for designers to develop applications based on RM500Q-GL module and to test basic functionalities of it.

2.1. Key Features

The following table describes the detailed features of RMU500-EK.

Table 1: Key Features

Features	Description
Power Supply	DC supply: +5 V/ 2.5 A for the EVB
M.2 Interface	Support RM500Q-GL
(U)SIM Interface	Support (U)SIM card: 2.95/1.8 V
USB Interface	USB 3.1 & USB 2.0
Status Indication	2 LEDs available for signal indication
Physical Characteristics	Size: 100 mm × 60 mm

2.2. Component Placement of the EVB

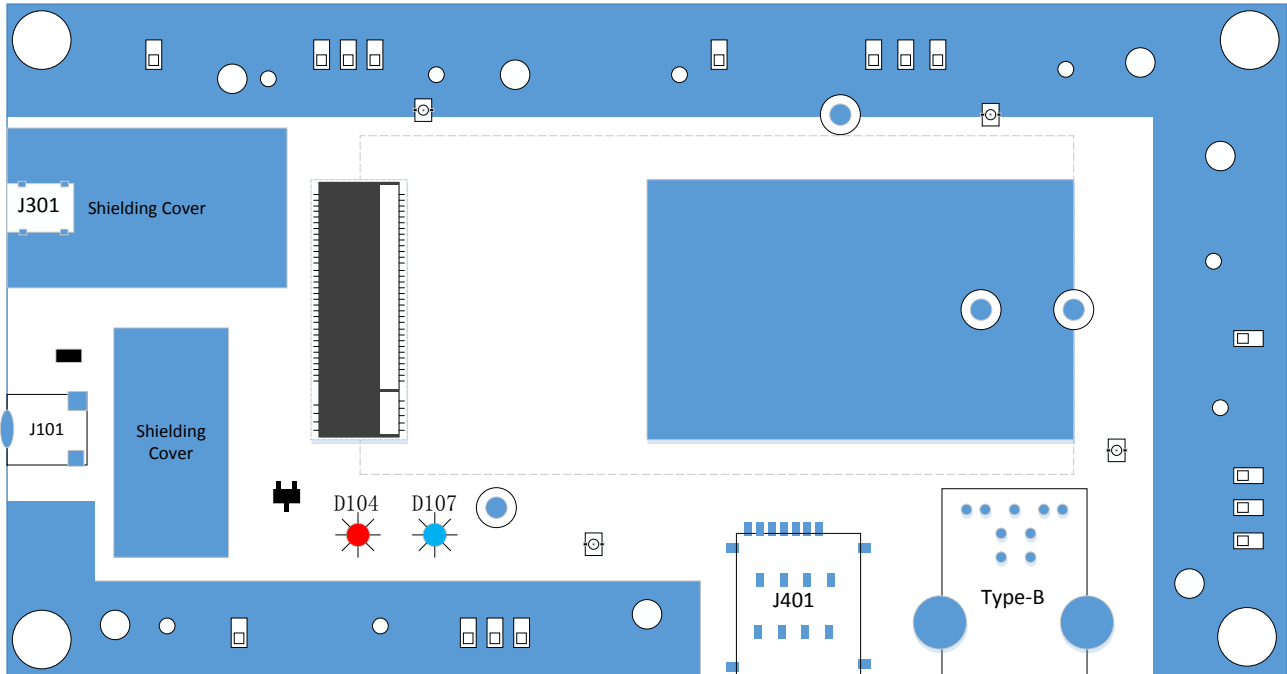

Figure 1: Component Placement of the EVB (Top View)

Table 2: Interfaces and Functions of the EVB

Interfaces	Reference Designators	Description
Power Supply	J101 (Power Jack)	The power jack on the EVB Typical supply voltage: +5 V/ 2.5 A
	J301 (Type-C USB)	Type-C USB interface Typical supply voltage: +5 V/ 2 A
M.2 Interface	J201	The M.2 connector for the module
USB Interface	J301	USB interface
(U)SIM Interface	J401	(U)SIM card connector
Indicator LEDs	D104 (POWER_LED)	Power indicator, indicating whether the module's power supply is ready.
	D107 (WWAN_LED)	RF status indicator

2.3. Top View of the EVB

Top view of the EVB is exhibited by the figure below.

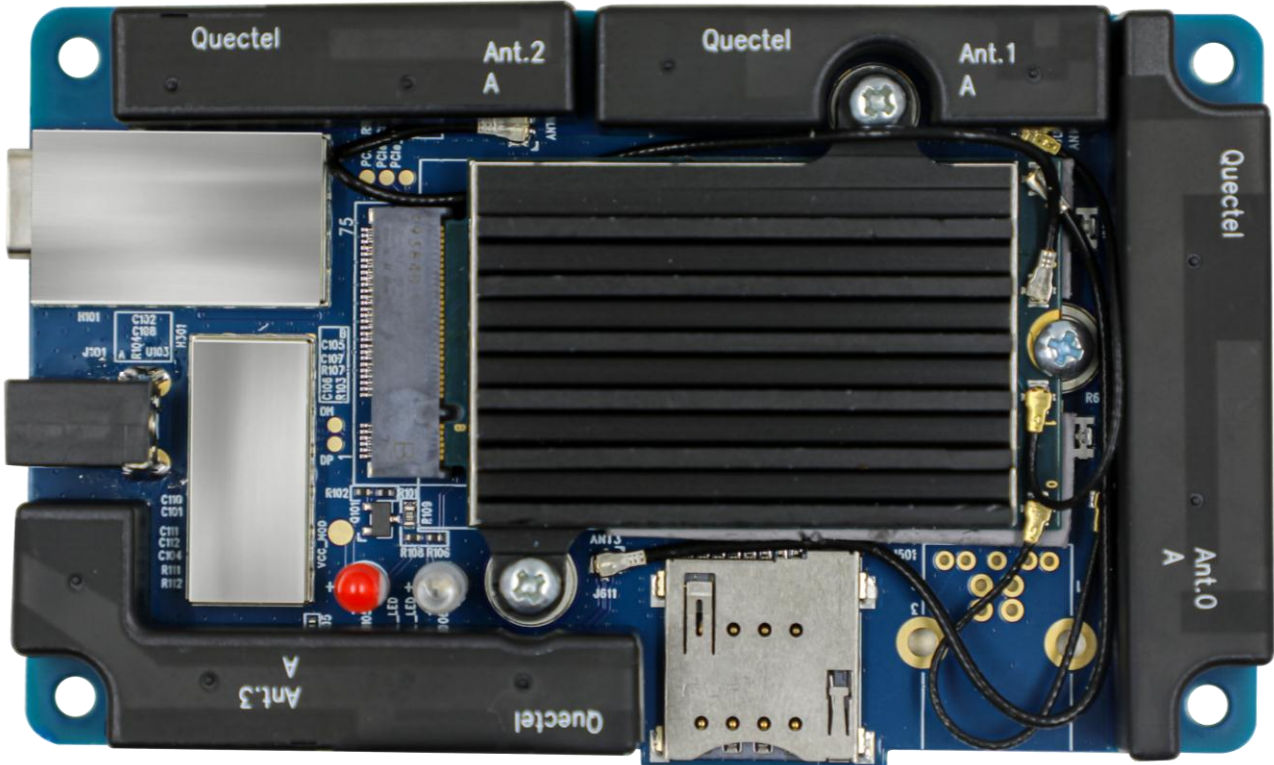

Figure 2: EVB Top View

2.4. EVB Kit Accessories

All accessories for the EVB are listed in the following table.

Table 3: Accessories List

Items	Description	Quantity
Cables	Type-C to dual Type-A cable	1
	RF cables	4
Antennas	Antennas with brackets	4

Silicone	Silicone soft pad	1
Heatsink	Black anodized AL6063	1
USB Flash Drive	Including the related documents, tools, and drivers for the module and RMU500-EK.	1
Screws	Used to clamp the module, antennas and heatsink on the EVB	19

3 Components/Interfaces

3.1. Components/Interfaces of the EVB

This chapter mainly describes the application of the following EVB interfaces:

- Power supply
- M.2 interface
- USB interface
- (U)SIM interface
- RF cables and antennas

It also provides information about the status indicator LEDs to help you use the EVB.

3.1.1. Power Supply (J101/J301)

The EVB can be powered by an external power adapter through the power jack (J101) on the EVB. It can be also powered by the USB interface through the power jack (J301) on the EVB.

The following figure shows the power supply interfaces of the EVB.

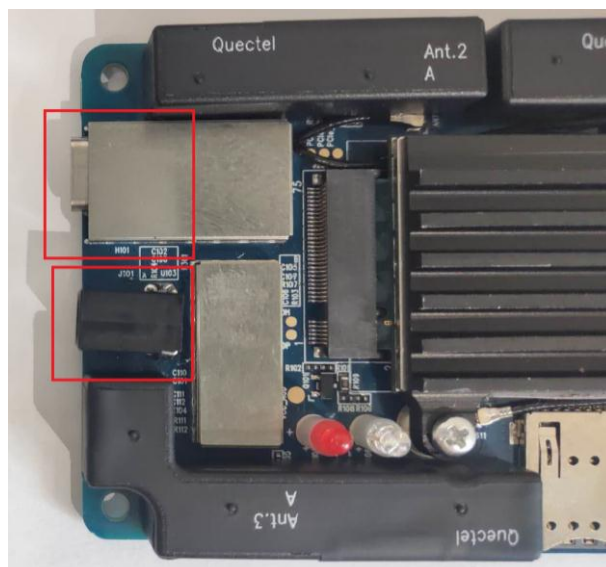

Figure 3: EVB Power Supply Interfaces

3.1.2. M.2 Interface (J201)

The M.2 connector is designed to accommodate the module. The following figure shows the M.2 connector on RMU500-EK..

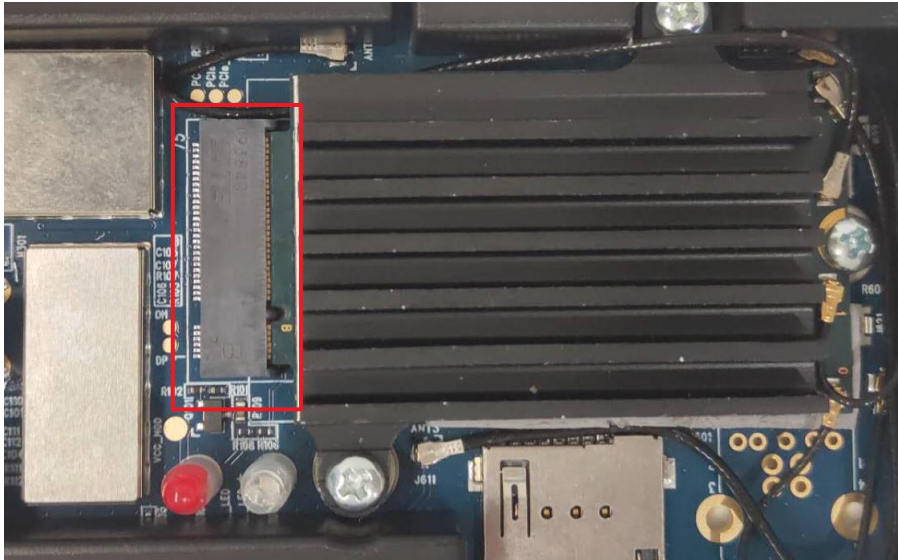

Figure 4: M.2 Connector on the EVB

3.1.3. USB Interface (J301)

The EVB provides a Type-C USB connector J301 for the connection with a host.

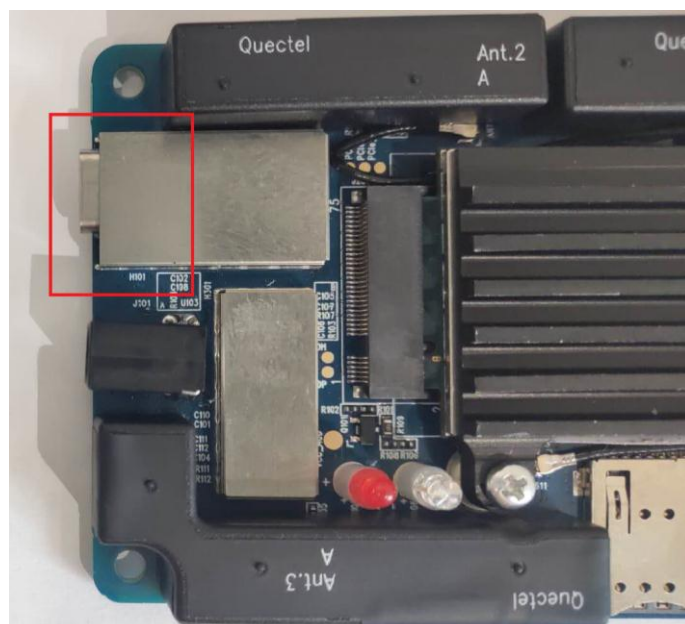

Figure 5: USB Connector

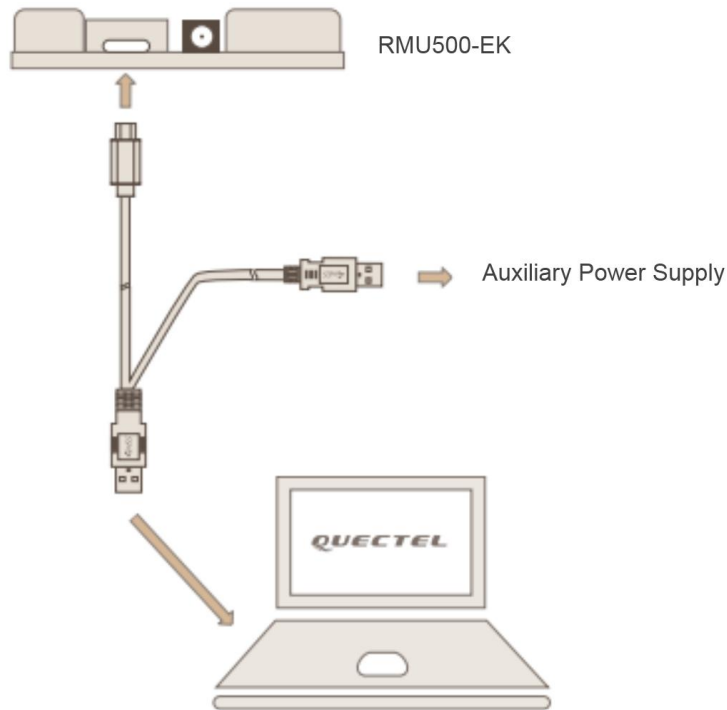

Figure 6: Connection Between PC and EVB

One end of Type-A is connected to the computer, and, when necessary (e.g. when power supply from the Type-A connected to the PC is inadequate), the other end is connected to the auxiliary power supply.

3.1.4. (U)SIM Interface (J401)

The EVB has an 8-pin push-push type (U)SIM card (1.8/2.95 V) connector J401. The following figure shows a simplified connecting schematic for J401.

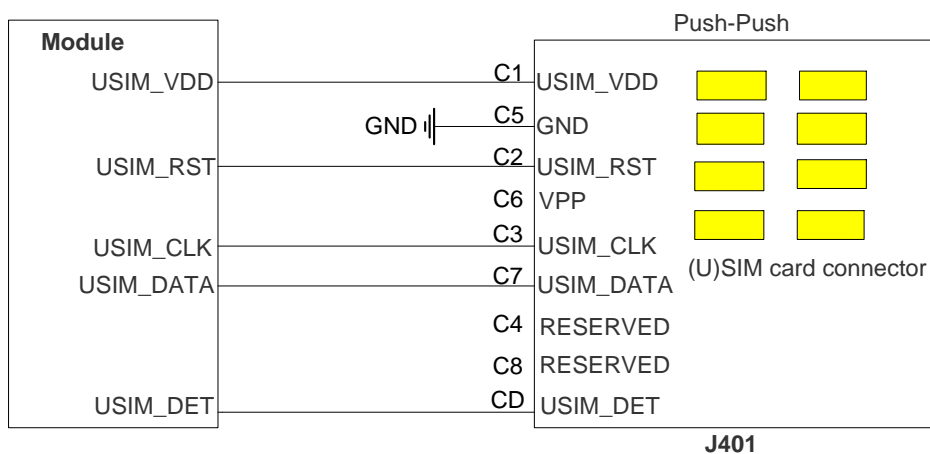

Figure 7: Simplified Connecting Schematic for (U)SIM Card Connector J401

The figure and table below illustrate the pin assignment and pin definition of (U)SIM card connector J401.

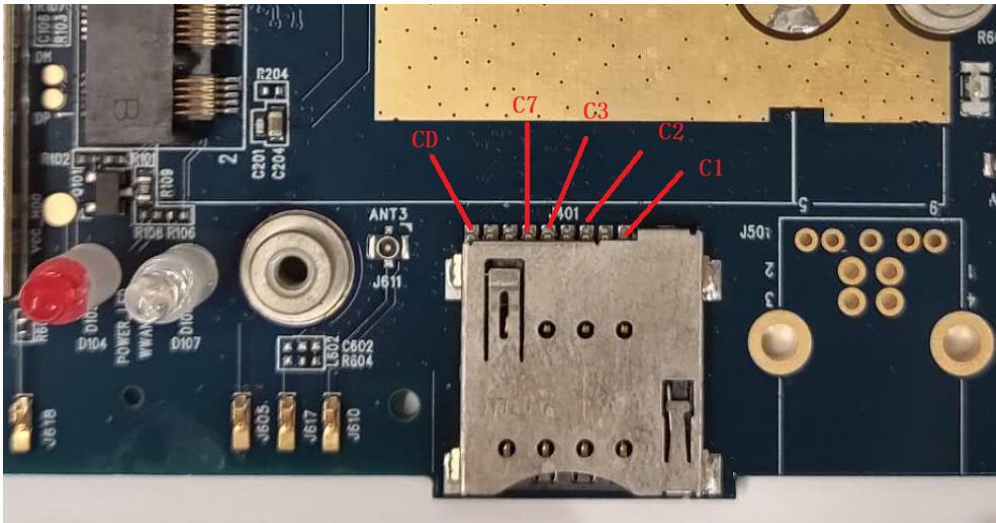

Figure 8: Pin Assignment of (U)SIM Card Connector J401

Table 4: Pin Definition of J401

Pin No.	Pin Name	I/O	Function
C1	USIM_VDD	PO	(U)SIM card power supply
C2	USIM_RST	DO	(U)SIM card reset
C3	USIM_CLK	DO	(U)SIM card clock
C4	RESERVED	-	Not connected
C5	GND	-	Ground
C6	VPP	-	Not connected
C7	USIM_DATA	I/O	(U)SIM card data
C8	RESERVED	-	Not connected
CD	USIM_DET	DI	(U)SIM card insertion detection ¹⁾

NOTE

¹⁾ USIM_DET function of RM500Q-GL module is under development.

3.1.5. Status Indicator (D104/D107)

The EVB provides two status indicator LEDs D104 and D107. The following figure shows the positions of these indicators.

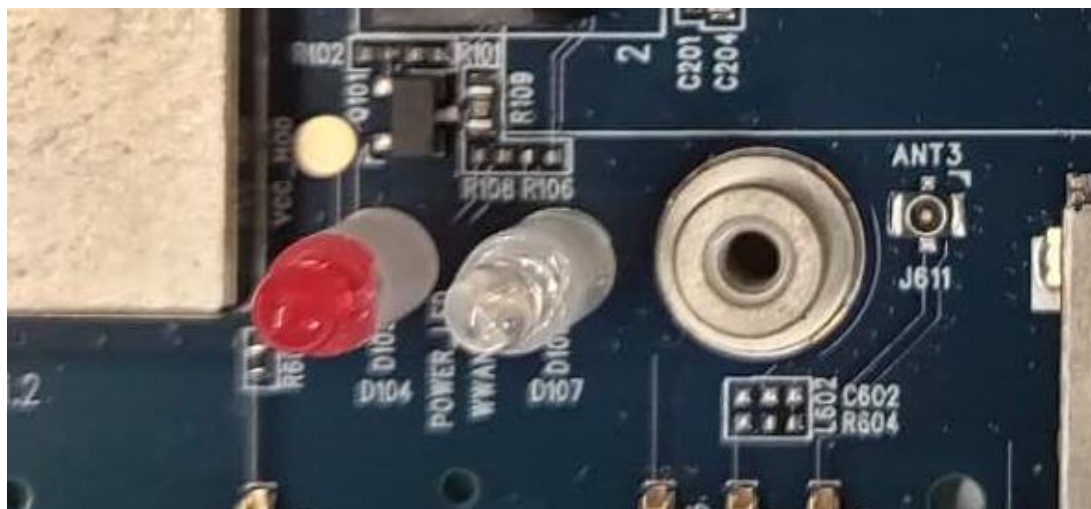

Figure 9: Status Indicators

Table 5: Description of Status Indicator LEDs

Reference Designators	Description
D104	Indicates whether the power supply for the module is ready. Light on: Power on light off: Power off
D107	RF status indicator for the module. Light on: RF function is enabled; light off: RF function is disabled.

3.1.6. RF Cables and Antennas

3.1.6.1. Antenna Design

The following figure is a typical reference design for the antennas.

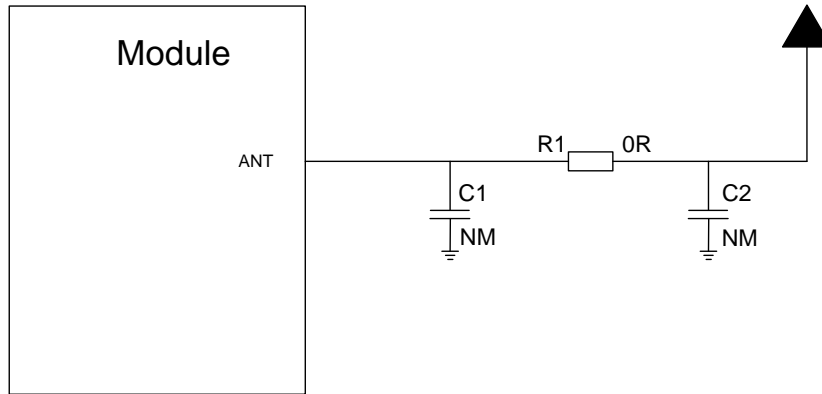

Figure 10: Reference Design for Antennas

The matching circuit is composed of C1, C2 and R1 for antenna impedance modification. By default, the value of R1 is 0 Ω , while C1 and C2 are not mounted.

3.1.6.2. Antenna Efficiency

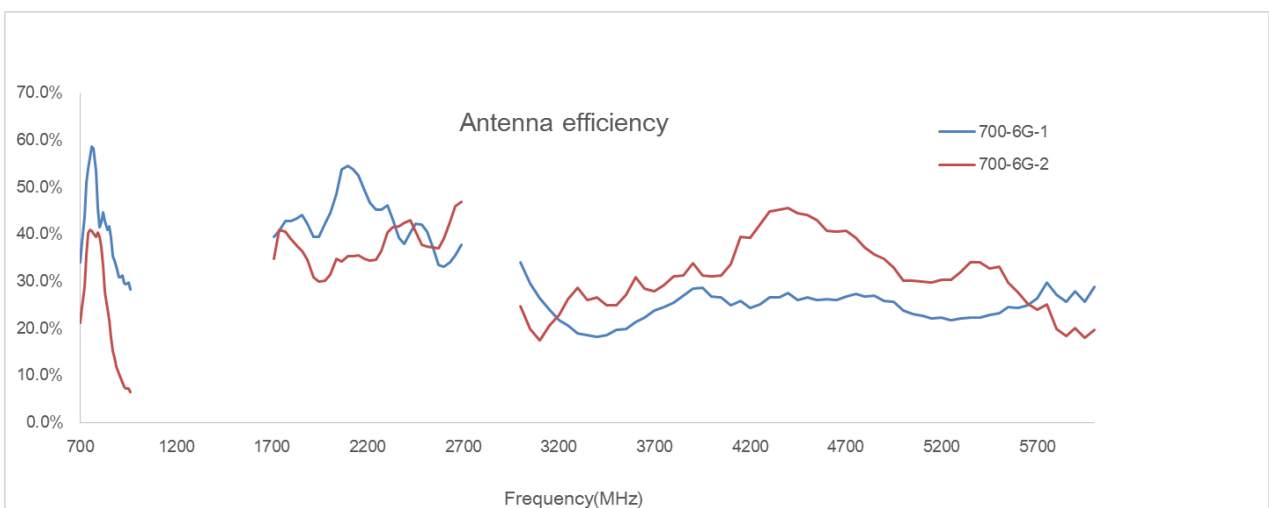

Figure 11: Antenna Efficiency at 700–960 MHz and 1.7–6 GHz

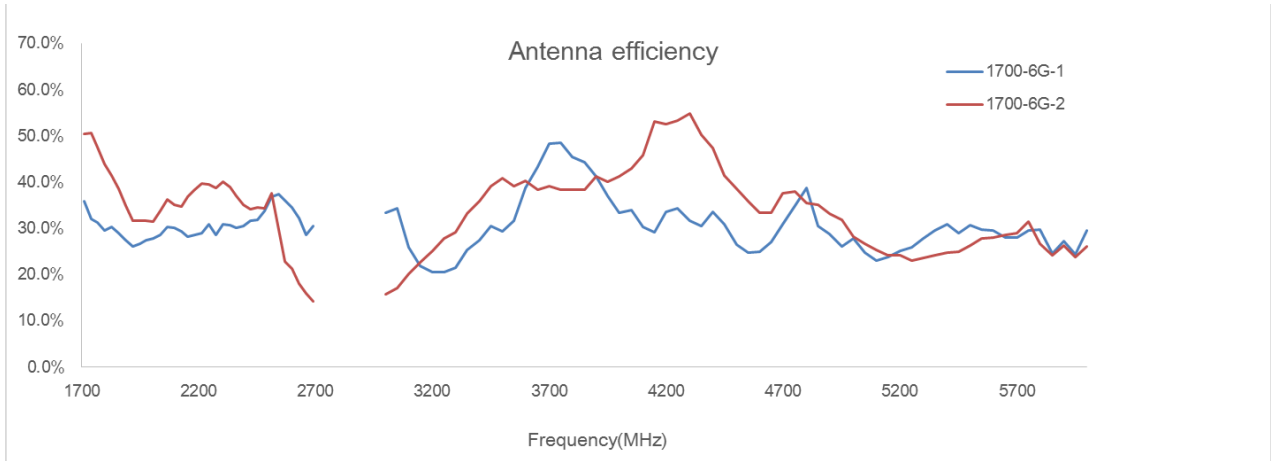

Figure 12: Antenna Efficiency at 1.7–6 GHz

NOTE

All measurements are done for the antenna mounted on RMU500-EK PCB with VNA Agilent 5071C and OTA chamber.

3.1.6.3. Antenna Specification

The specification of antennas are provided in the following table.

Table 6: Antenna Specification

Antenna	Specification
Ant.0	Frequency Range: 0.7–6 GHz Input Impedance: 50 Ω
Ant.1	Frequency Range: 1.7–6 GHz Input Impedance: 50 Ω
Ant.2	Frequency Range: 1.7–6 GHz Input Impedance: 50 Ω
Ant.3	Frequency Range: 0.7–6 GHz Input Impedance: 50 Ω

3.2. Component Assembling Steps

Please follow these steps to assemble the product.

Step 1: Insert four RF cables.

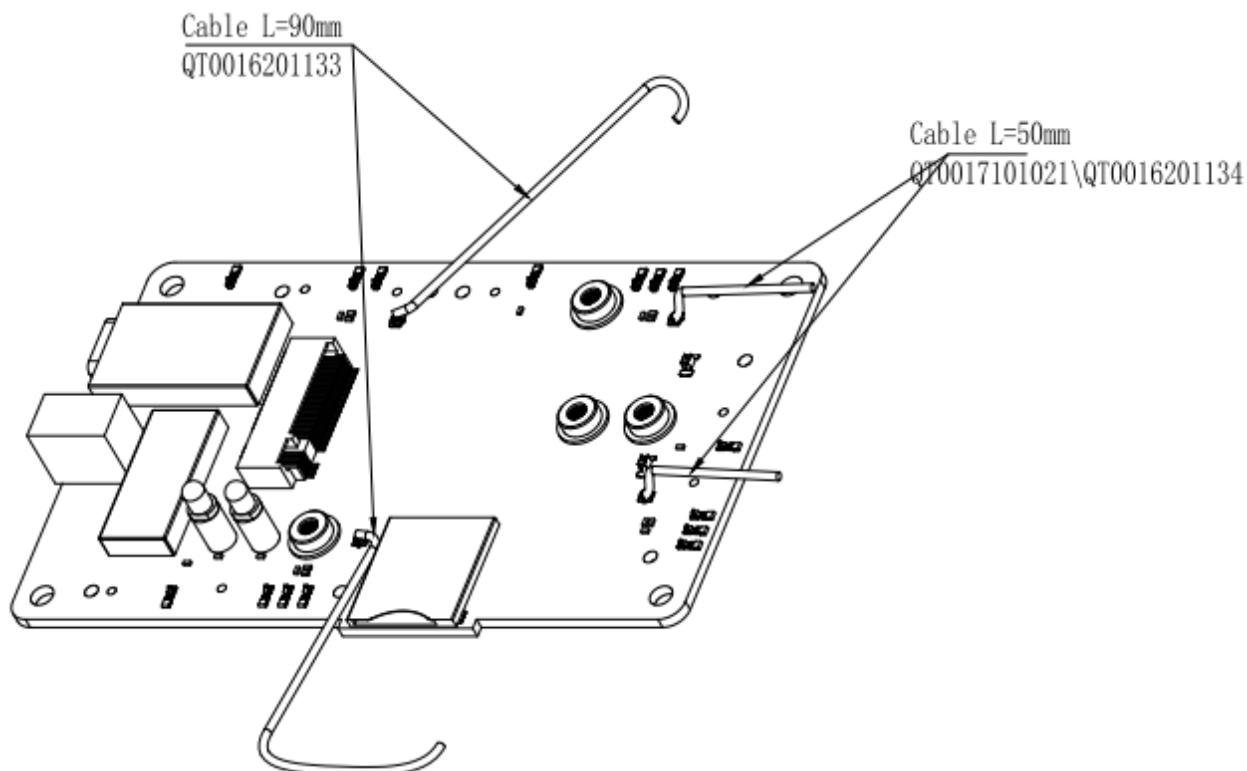

Figure 13: Assembling Step 1

Step 2: Stick the thermal pad, insert the module into the M.2 connector and tighten the screw.

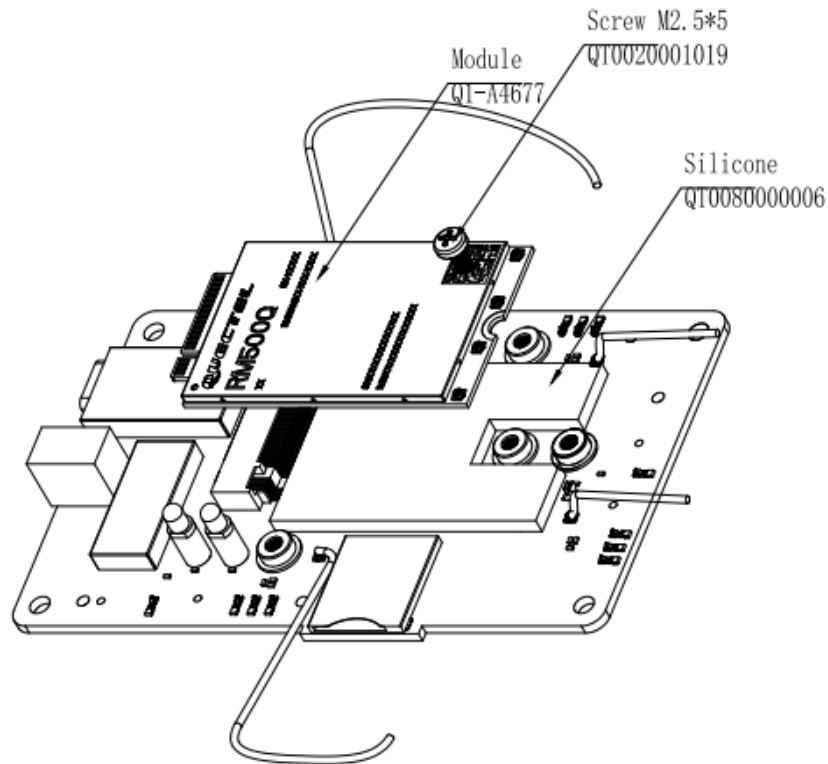

Figure 14: Assembling Step 2

Step 3: Connect the EVB and the module with RF cables as illustrated by the figure below.

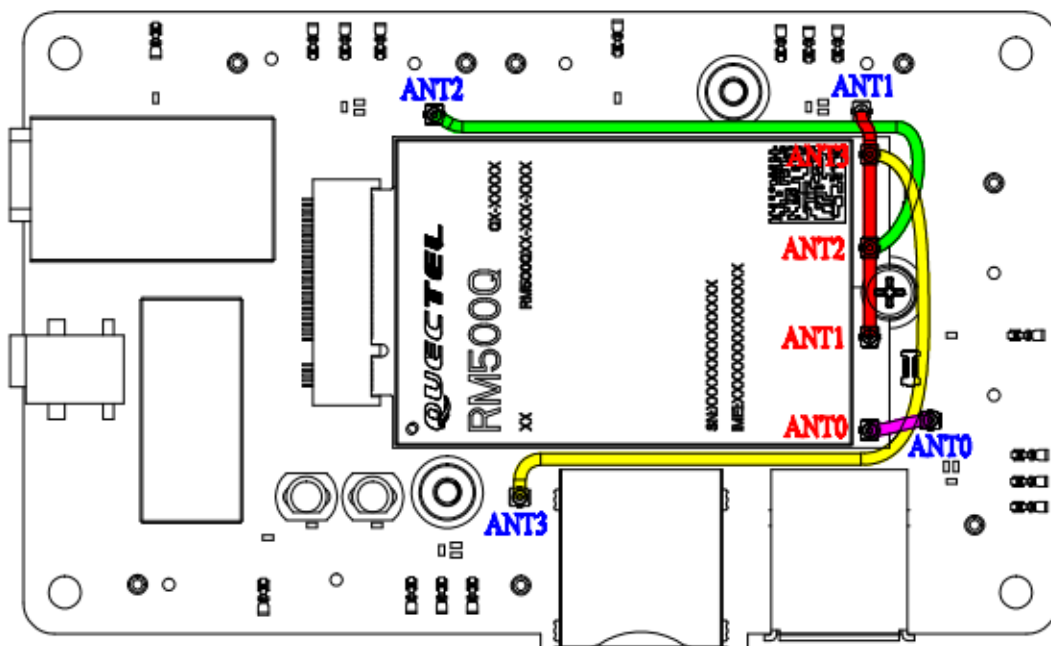

Figure 15: Assembling Step 3

Step 4: Place the heatsink on the module and tighten the screws.

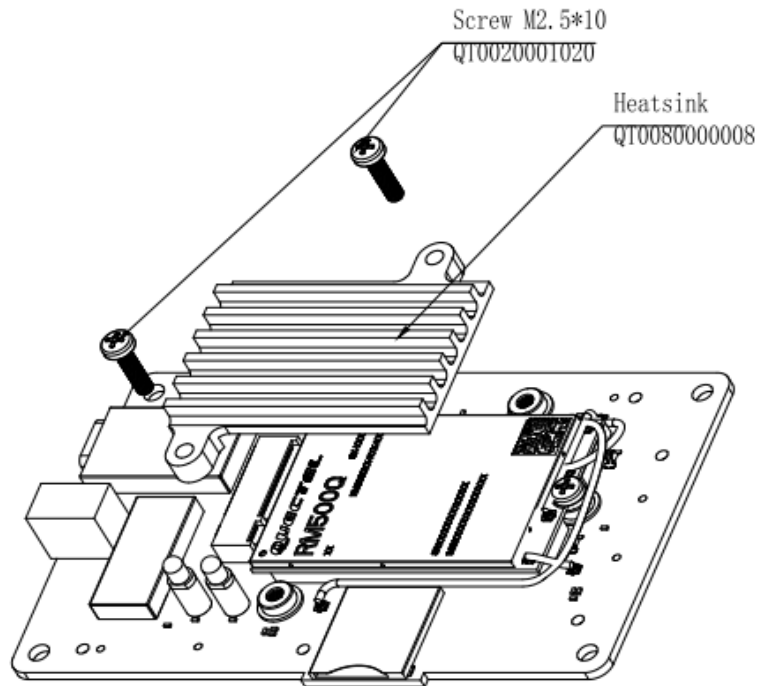

Figure 16: Assembling Step 4

Step 5: Install the antennas in turn and tighten the screws.

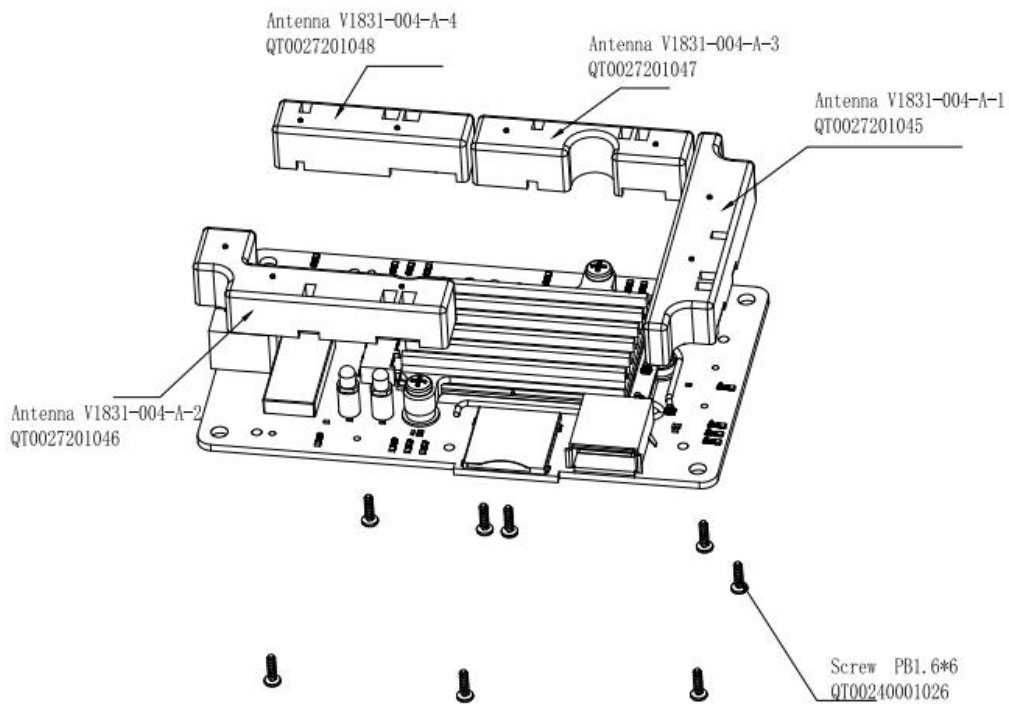

Figure 17: Assembling Step 5

Step 6: Assembling finished.

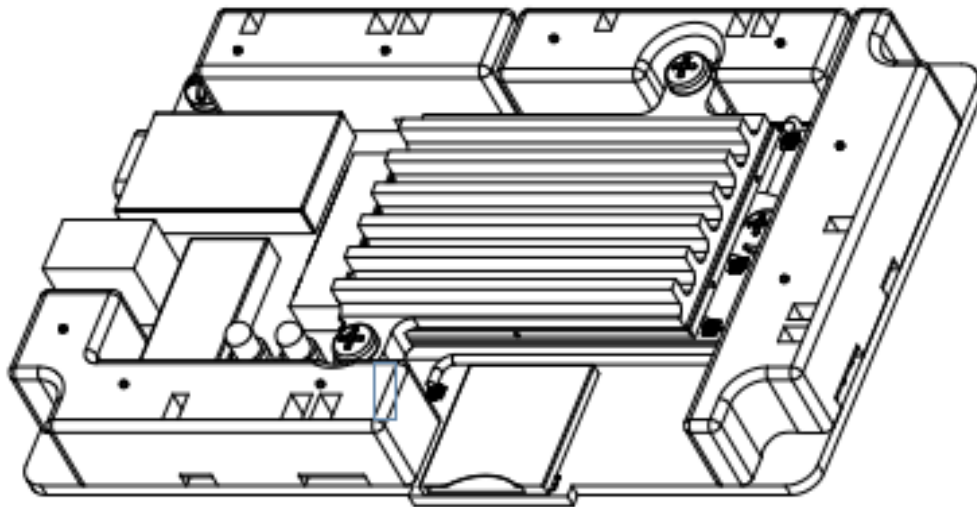

Figure 18: Assembling Step 6

4 EVB Operation Procedures

This chapter introduces how to use the EVB for the testing evaluation of the module.

4.1. Turn on the Module

1. Finish the assembling steps in **Chapter 3.2**.
2. Insert a (U)SIM card into the (U)SIM card connector on the EVB.
3. Insert the USB cable (Type-C to dual Type-A), and connect one Type-A end to the computer and the other end to the auxiliary power supply. The Type-C end is connected to the EVB. Power on the EVB and the module will be turned on automatically.

4.2. Communication Via the USB Interface

1. Turn on the module according to the procedure in **Chapter 4.1**.
2. Connect the EVB and a PC with the USB cable through USB interface, and then run the driver disk on the PC to install the USB driver. For details about USB driver installation, see **document [1]**.



Figure 19: USB Ports

3. Install and then use the tool, QCOM, provided by Quectel to realize the communication between the module and the PC.

The following figure shows the COM Port Setting in QCOM: select correct “**COM Port**” (USB AT Port which is shown in the figure above) and set correct “**Baudrate**” (such as 115200 bps). For more details about QCOM usage and configuration, see **document [2]**.

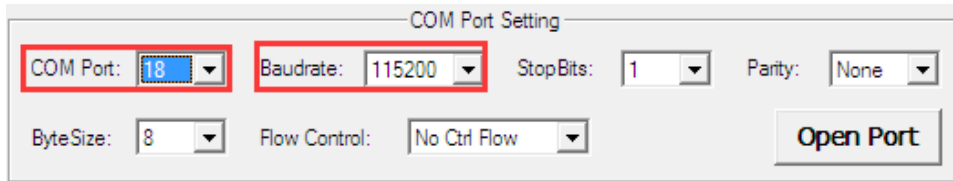

Figure 20: COM Port Setting Field on QCOM (USB AT Port Connection)

4.3. Firmware Upgrade

The firmware of the module is upgraded via USB port by default, please follow the procedures below to upgrade the firmware.

1. Install and open the firmware upgrade tool, QFlash, on the PC and then turn on the module according to the procedures in **Chapter 4.1**.
2. Click the “**COM Port**” dropdown list and select the Port No. corresponding to “Quectel USB DM Port”.
3. Click the “**Load FW Files**” button and choose the firmware package.
4. Click the “**Start**” button to upgrade the firmware.

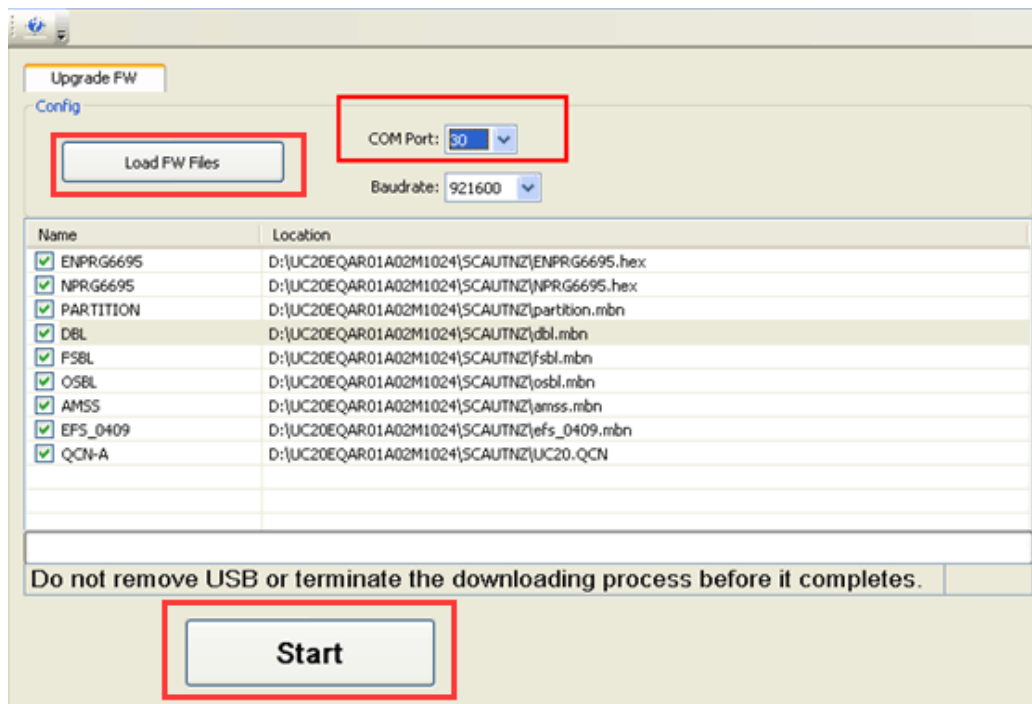

Figure 21: Configurations for Firmware Upgrade

For more details about QFlash usage and configuration, see *document [3]*.

4.4. Turn Off the Module

There are two methods to turn off the module.

- Hardware method: the module will be turned off after the USB cable is disconnected.
- Software method: the module can be turned off with the AT command **AT+QPOWD**.

5 Appendix References

Table 7: Related Documents

SN	Document Name	Description
[1]	Quectel_LTE&5G_Windows_USB_Driver_Installation_Guide	Installation guide of USB driver for LTE&5G modules on Windows system
[2]	Quectel_QCOM_User_Guide	User guide for QCOM tool
[3]	Quectel_QFlash_User_Guide	User guide for QFlash tool
[4]	Quectel_RG50xQ&RM5xxQ_Series_AT_Commands_Manual	AT commands manual for RM500Q-GL, RM500Q-AE, RM502Q-GL, RM502Q-AE, RM510Q-GL, RG500Q series, and RG502Q-EA module
[5]	Quectel_RM500Q-GL_Hardware_Design	Hardware design for RM500Q-GL module

Table 8: Terms and Abbreviations

Abbreviation	Description
COM	Communication Port
DC	Direct Current
DI	Digital Input
DO	Digital Output
EVB	Evaluation Board
GND	Ground
GNSS	Global Navigation Satellite System
I/O	Input/Output
LED	Light Emitting Diode
NC	Not Connected

PC	Personal Computer
PCB	Printed Circuit Board
PO	Power Output
RF	Radio Frequency
SD	Secure Digital
SIM	Subscriber Identity Module
UART	Universal Asynchronous Receiver & Transmitter
USB	Universal Serial Bus
(U)SIM	(Universal) Subscriber Identity Module
